

KF

5600M/6700M

Vertical Machining Center for Machining High-quality Large Molds

WIA Machine Tools Vertical Machining Center

WIA MACHINE TOOLS

Technical Leader

The Vertical Machining Center KF5600M/6700M, designed by WIA machine tools with years of expertise and the latest technology, provides the high performance necessary for machining high quality molds.

		KF5600M	KF6700M
Table Size (L×W)	mm(in)	1,250×560 (49.2"×22")	1,500×670 (59"×26.4")
Max. Load Capacity	kg(lb)	1,000 (2,205)	1,300 (2,866)
Spindle Taper	-	BBT40 [HSK-A63]	
Spindle Speed	r/min	20,000	
Sp. Power (Max./Cont.)	kW(HP)	22/18.5 (30/25)	
No. of Tools	EA	30 [40, 60]	
Travel (X/Y/Z)	mm(in)	1,100/560/520 (43.3"/22"/20.5")	1,300/670/635 (51.2"/26.4"/25")
Rapid Traverse Rate	m/min	36/36/30	

[]: Option

KF

5600M/6700M

Vertical Machining Center for Mold Machining

- Built-in main spindle for processing high quality mold products
- High-speed roller type LM guide in all axis
- Enhanced chip processing capabilities by applying the upper-type conveyor
- Hynudai WIA mold package for optimal mold product machining
- Improved user convenience by applying the latest controller of FANUC



01 BASIC STRUCTURE

High Speed & Productivity Vertical Machining Center for Mold Machining

ATC & Magazine

- No. of Tools : 30 [40, 60] EA
- Max. Tool Length : 300 mm (11.8")
- Tool Shank : BBT40

High Precision Spindle

- Built-in Spindle : 20,000 rpm
- Spindle Heat Distortion Compensation Device Standard (Sensorless)

Table

ITEM	Size (X/Y) / Load Capa.
KF5600M	1,250×560 mm / 1,000 kg (49.2"×22" / 2,205 lb)
KF6700M	1,500×670 mm / 1,300 kg (59"×26.4" / 2,866 lb)

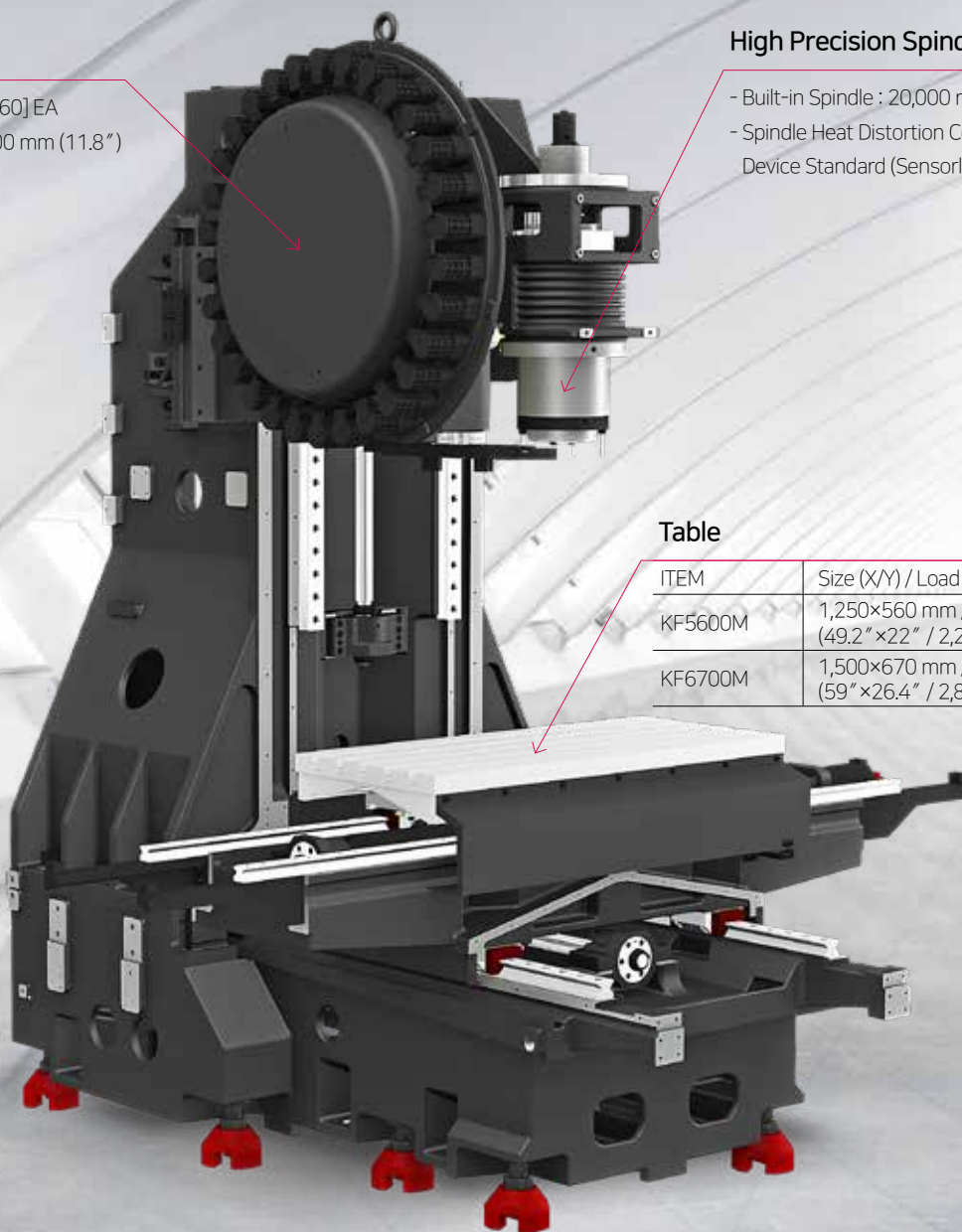

HIGH-PRECISION, SPEED & LARGE WORKING AREA

HIGH-PRECISION STRUCTURE

Optimal Structural Analysis

KF5600M/6700M is designed to have optimal structure through WIA machine tools's unique structural analysis. In particular, enhancement of bed and column's rigidity makes excellent performance even in heavy duty cutting.

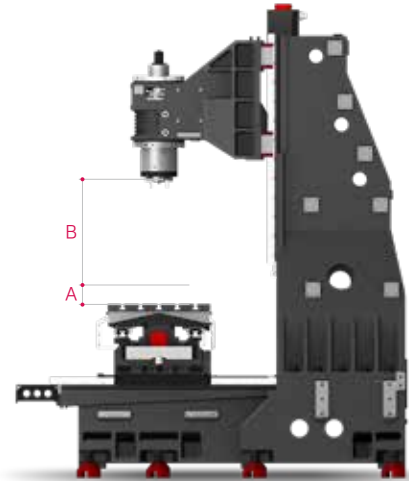

Distance from Table Top to Spindle Nose

KF5600M (A~B)

150~670 mm (5.9"~26.4")

KF6700M (A~B)

150~785 mm (5.9"~30.9")

TABLE

Compared to competitive machines, the KF5600M/6700M has a large working capacity to make setup easier and provide convenience to the operator.

Model	Size	Load Capacity
KF5600M	1,250×560 mm (49.2"×22")	1,000 kg (2,205 lb)
KF6700M	1,500×670 mm (59"×26.4")	1,300 kg (2,866 lb)



INCREASE OF SADDLE RIGIDITY

The KF6700M with the largest saddle among the KF5600M/6700M has almost same level of saddle-end displacement as the base model.

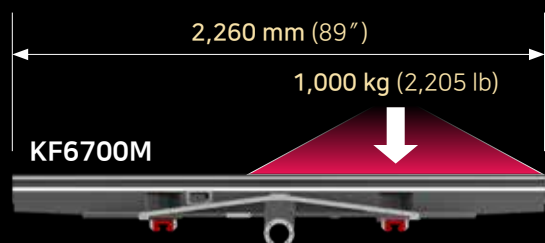

KF5600/6700M

02 HIGH-SPEED FEED

Highest Quality, High-speed Vertical Machining Center

Travel (X/Y/Z)

KF5600M

1,100/560/520 mm
(43.3"/22"/20.5" [25"])

KF6700M

1,300/670/635 mm
(51.2"/26.4"/25")

Rapid Traverse Rate (X/Y/Z)

KF5600M

36/36/30 m/min
(1,417/1,417/1,181 ipm)

KF6700M

36/36/30 m/min
(1,417/1,417/1,181 ipm)

REDUCED NON-CUTTING TIME & IMPROVED FEED PRECISION

GUIDE WAY

High-Speed Roller LM Guideway

Linear roller guideways are applied to reduce non-cutting time and bring high rigidity. Each axis is directly connected to a highly reliable digital servo motor to provide high rigidity and minimal thermal displacement.

Improvement in Slide Cover

The increased slope of slide cover makes chip disposal easier and minimizes slide cover breakage.



Double Anchored Ball Screw

The pretensioned ball screw minimizes the expansion and contraction according to the heat and further reinforces the rigidity by the double anchor support method.

In addition, the coupling of the ballscrews and the highly reliable digital servo motors are connected by **metal plate couplings**, to reduce coupling breakage and backlash.

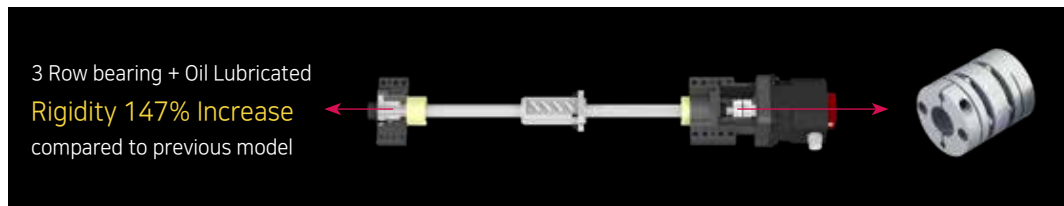

Increase in Durability of Z-axis ball screw

Lifetime of the bearing has been greatly increased by optimizing the spindle structure and lubrication method.

※ Customer Actual Data



KF5600/6700M

03 HIGH PRECISION SPINDLE

Excellent machining performance with high-precision spindle

Type

Built-in

Sp. Speed

20,000 rpm

Motor (Max./Cont.)

22/18.5 kW (29.5/25 HP)

Torque (Max./Cont.)

98/80 N·m (72.3/59 lbf·ft)

KF5600M/6700M 20,000rpm (Built-in)

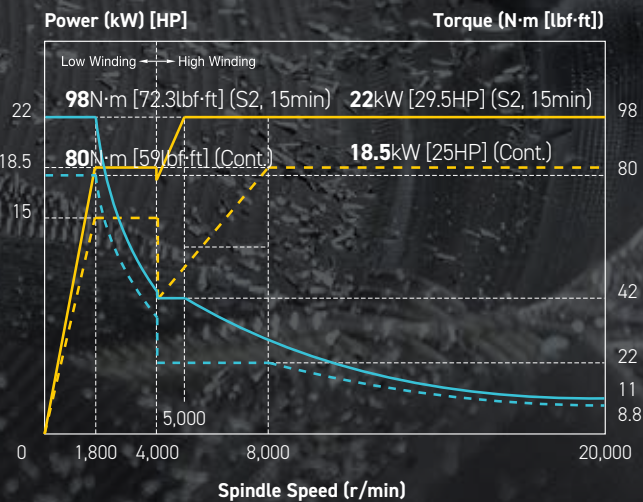

HIGH-PERFORMANCE, HIGH-PRECISION SPINDLE

SPINDLE

Built-in Spindle

The 20,000rpm built-in spindle can minimize vibration transmitted to the spindle. It allows excellent machining performance in mold and high-precision products.

Spindle Cooling

The spindle cooling system minimizes thermal displacement which can happen during lengthy machining operations, and offers continued accuracy based on the thermal stability.

※ Improved cooling capability with chilling through head frame

Through Spindle Coolant (20/30/70 bar) **OPTION**

Through Spindle Coolant is exceedingly useful when drilling deep holes. It helps increase the lifetime of the tool, while decreasing cycle time.

The improved quality of rotary joint prevents oil leakage.

Dual Contact Spindle

The Big Plus spindle system (BBT40) provides dual contact between the spindle face and the flange face of the tool holder.

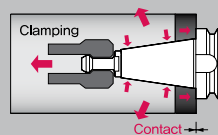

HSK TOOL HOLDER

OPTION

HSK tool holder is utilized for precise positioning with less expansion in the spindle taper during high speed rotation. This ensures an excellent level of precision for die mold machining.



HSK-A63

KF5600/6700M

04 ATC & MAGAZINE

High Productivity Achieved with High Rigidity, Accuracy Machining

No. of Tools

30 [40, 60] EA (KF4600 II : Opt. 40 EA)

Tool Selection Method

Random [Fixed]

Max. Tool Length

300 mm (11.8")

Max. Tool Weight

8 kg (18 lb)

Tool Shank

BBT40 [HSK-A63]

Max. Tool Dia. (W.T/W.O)

30T : Ø80/125 [40T : Ø76/125] [60T : Ø75/127] mm
(30T : Ø3.1"/Ø4.9" [40T : Ø3"/Ø4.9"] [60T : Ø3"/Ø5"])

[] : Option

HIGH RIGIDITY, TOOL CHANGE SYSTEM

ATC & MAGAZINE

High Speed ATC

Position control through twin arm ATC on servo motors has been improved drastically. In addition, tool exchanging has become easier, reducing specific cutting time tremendously.

Position control on the Twin Arm ATC has improved drastically. The twin arm ATC enables faster tool change and increased productivity.



Tool Change Time (C-C)

KF5600M : 3.2 sec KF6700M : 3.5 sec

Magazine

The tool magazine holds **30 tools** as standard and **40, 60 tools** as an option. Due to the wider selection of tools and the random tool selection method, tool change time has improved.

[Fixed : Option]

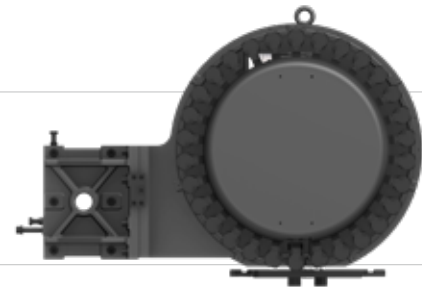

Max. Tool Length / Dia.



05 USER CONVENIENCE

Various Devices for User Friendly

CHIP DISPOSAL SOLUTION & COOLANT UNIT

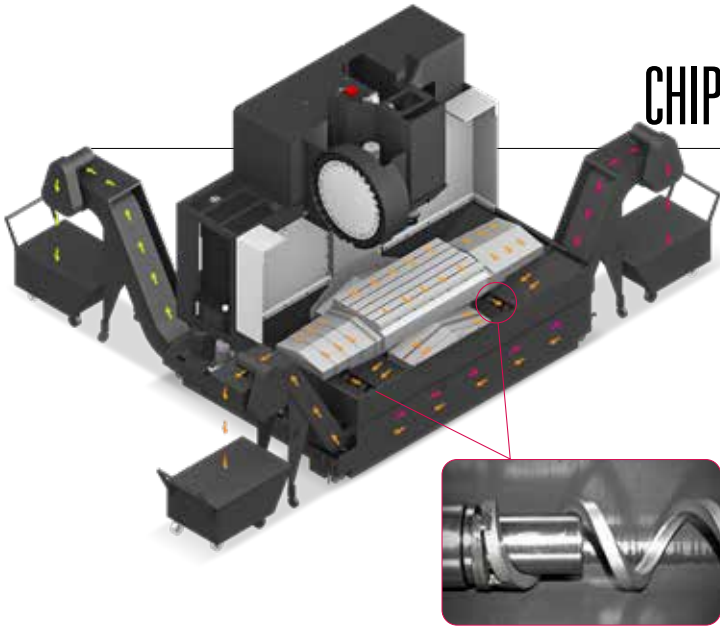

Cutting Air Blow (Opt.)



Bed Flushing Coolant (Opt.)



Gun Coolant (Opt.)



Air Gun (Opt.)

Interior Screw Chip Conveyor (Forward / Backward Rotation Function)

Dual screw type chip conveyors are located at each side of the bed which makes it convenient to remove chips. The interior screw and the chip conveyor operate at the same time and can be controlled separately at the time of prior consultation.

(Three screws for rear-type conveyor: 2 sides + 1 front)

Furthermore, chip disposal capability significantly has been improved due to optional bed-flushing coolant.

Upper-type Conveyor (Std.)

The upper type chip conveyor is applied as a standard to efficiently remove chips generated during machining. In addition, the 365 liter (KF5600M) of large coolant tank provides a seamless machining environment even with large amounts of coolant.

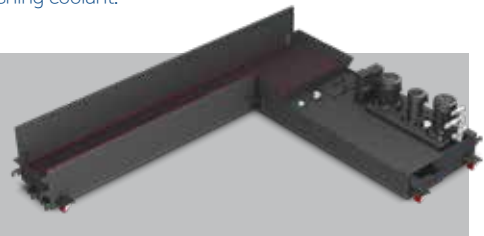

Hinge	Chip Type : Roughing Chip, Long Chip, Chip complex	Material : SS41, 45C, Cast Steel	Side/Rear Direction
	Highly efficient when disposing a lot of chips. Capable of handling stringy chips..		
Scraper	Chip Type : Finely broken chip blown out	Material : cast Iron, Nonferrous	
	Convenient for shortly cut chips.		
※ Screw	Chip Type : The lower portion of micro-chips	Material : Steel, Casting	
	Compresses and ejects chips to reduce chip Trouble.		
※ Drum Filter	Chip Type : Powder, Micro Chip	Material : AL	
	Advantageous in precision, as the chips do not flow in to the coolant nozzle.		

※ When ordering a screw or drum filter chip conveyor, prior consult with hyundai wia's sales person.

PRECISION SYSTEM



Linear Scale

Linear scales increase positioning accuracy and reduce distortion caused by thermal growth, thus ensuring a more accurate finished part



Touch Sensor

Workpiece coordinate values can be set automatically using the optional spindle probe.



TLM (Laser & Touch)

Tool lengths and diameters can be set automatically using the optional tool setter. This can also be used to monitor attrition and detect broken tools.

ECO SYSTEM



Oil-skimmer

Separated oil-skimmer and coolant tank to keep coolant free of tramp oils.



Automatic Grease Supply Unit

Optional automatic grease lubrication eliminates the need for an oil skimmer and significantly reduces maintenance costs against oil lubrication.



MQL (Minimal Quantity Lubrication)

The goal of this system is to spray only the amount of lubricant required to prevent heat and chip build up at the cutting tool or work piece face.



NC ROTRY TABLE & HYDRAULIC SUPPLY UNIT

Various shapes of products can be processed when using NC Rotary Table. In addition, 100 bar of high pressure hydraulic unit for the fixture increases the tightening power of the teeth.

KF5600/6700M

06 MOLD PACKAGE

Powerful Mold Package, WIA Machine Tools Mold All in One

MOLD PACKAGE

To enhance mold machining, the "HWM ALL-IN-ONE" is provided as an option feature for KF5600M/6700M. This ensures accurate and high quality surface finishing and contouring. (Mold1 Package : Standard)



WMT ALL-IN-ONE



- ① High Speed Contouring Control (AICC II)
- ② Development S/W
HW-MCS (Selectable Process Conditions), HW-AFC (Adaptive Feed Control)
- ③ Main Spindle Cooling Device (8-channel) - Maintain spindle temperature (heat sensor)
- ④ Cutting Air Blow - Cutting air blow is provided for mold machining.
- ⑤ Auto Tool Measuring Device - Detects and sets tool length, and attrition (Graphic User Interface included)

Thermal Displacement Compensation Device

Cooling system & Lubrication system

Thermal displacement of the spindle is minimized by the use of cooling techniques. This provides high accuracy when machining at high speed.

T.D.C With PT100 Sensor

Interface

T.D.C With Disp. Sensor

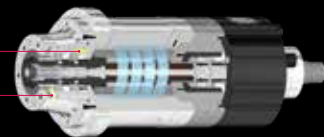

MOLD PACKAGE OPTION

1 Package : Standard 2, 3, 4 Package : Option

WMT ALL IN ONE		1 Package	2 Package	3 Package	4 Package
20,000 rpm Built-in Spindle		●	●	●	●
FANUC 31i-B Controller		●	●	●	●
High Performance Feed motor		●	●	●	●
High Performance Ball Screw		●	●	●	●
AICC II Package	200 block	●	●		
	600 block			●	
	1,000 block				●
S/W : HW-MCS, HW-AFC		●	●	●	●
Auto Power Off		●	●	●	●
Spindle Heat Distortion Compensation Device		●	●	●	●
Cutting Air Blow		●	●	●	●
Auto Tool Measuring Device (TS27R)		●	●	●	●
Data Server 1GB			●	●	●

SPECIFICATIONS

Standard & Optional

● : Standard ○ : Option ☆ : Prior Consultation - : Non Applicable

Spindle		KF5600M	KF6700M
20,000rpm	Built-in	●	●
Spindle Cooling System		●	●
ATC			
ATC Extension	30	●	●
	40	○	○
	60	○	○
공구타입	BBT40	●	●
	HSK-A63	○	○
	CAT40/BCV40	○	○
U-Center	D'andrea	○	○
Pull Stud	45°	●	●
Table & Column			
T-Slot Table		●	●
NCRotary Table		☆	☆
High Column	300mm	-	-
Coolant System			
Std. Coolant (Main Spindle Nozzle)		●	●
Through spindle coolant*1)	20ba	○	○
	30bar, 20 ℓ	○	○
	70bar, 15 ℓ	○	○
	70bar, 30 ℓ	○	○
Top Cover		●	●
Shower Coolant		○	○
Gun Coolant		○	○
Bed Flushing Coolant		○	○
Air Gun		○	○
Cutting Air Blow		●	●
Tool Measuring Air Blow (Only for TLM)		○	○
Air Blow for Automation		☆	☆
Thru MQL Device (Without MQL)		☆	☆
Coolant Chiller (Sub Tank)		☆	☆
Power Coolant System (For Automation)		☆	☆
Chip Disposal			
Coolant Tank	350 ℓ (92.5 gal)	●	-
	370 ℓ (97.7 gal)	-	●
Interior Screw Chip Conveyor		●	●
Upper Chip Conveyor (Hinge)	Left	○	○
	Right	○	○
Flood Chip Conveyor (Hinge/Scraper)	Left	○	○
	Right	○	○
	Rear	○	○
Screw Type Chip Conveyor	Left	☆	☆
	Right	☆	☆
Drum Filter Type Chip Conveyor	Left	☆	☆
	Right	☆	☆
	Rear	☆	☆
Chip Wagon	Standard (180 ℓ [47.5 gal])	○	○
	Swing (200 ℓ [52.8 gal])	○	○
	Large Swing (290 ℓ [76.6 gal])	○	○
	Large Size (330 ℓ [87.2 gal])	○	○
	Customized	☆	☆
ETC			
Tool Box		●	●
Customized Color	Need for Munsel No.	☆	☆
CAD&CAM Software		☆	☆
Thermal displacement compensation		○	○

Electric Device		KF5600M	KF6700M
Call Light	1 Color : ●	●	●
Call Light & Buzzer	3 Color : ●●●	○	○
Electric Cabinet Light		○	○
Remote MPG		●	●
3 Axis MPG		○	○
Work Counter	Digital	○	○
Total Counter	Digital	○	○
Tool Counter	Digital	○	○
Multi Tool Counter	Digital	☆	☆
Electric Circuit Breaker		○	○
AVR (Auto Voltage Regulator)		☆	☆
Transformer	30kVA	-	-
	35kVA	○	○
Auto Power Off		●	●
Back up Module for Black out		○	○
Measuring Device			
Air Zero	TACO	○	○
	SMC	○	○
Work Measuring Device		○	○
TLM (Marposh/Renishaw/Blum)	Touch	●	●
	Laser	○	○
Tool Broken Detecting Device		☆	☆
Linear Scale	X/Y/Z Axis	○	○
Coolant Level Sensor (Only for Chip Conveyor, Bladder Type)		☆	☆
Environment			
Air Conditioner		○	○
Oil Mist Collector		☆	☆
Oil Skimmer (Only for Chip Conveyor)		○	○
MQL (Minimal Quantity Lubrication)		☆	☆
Fixture & Automation			
Auto Door	Std.	○	○
	High Speed	☆	☆
Auto Shutter (Only for Automatic System)		○	○
Sub O/P		☆	☆
NC Rotary Table/F	Single	○	○
	Channel	☆	☆
Control of Additional Axis	1Axis	○	○
	2Axis	☆	☆
External M Code 4ea		○	○
Automation Interface		☆	☆
I/O Extension (In & Out)	16 Contact	☆	☆
	32 Contact	☆	☆
Hyd. Device			
Hyd. Unit for Fixture	45bar	-	-
	70bar	○	○
	100bar	○	○
	Customized	☆	☆
S/W			
Dialogue Program (HW-DPRO)		○	○
DNC software (HW-eDNC)		○	○
Machine Monitoring System (HW-MMS Cloud)		☆	☆
Smart Guide-i : FANUC		☆	☆
Smart S/W		☆	☆

*1 : Please check the filter types with sales representative.

Specifications are subject to change without notice for improvement.

SPECIFICATIONS

External Dimensions (KF5600M)

unit : mm(in)

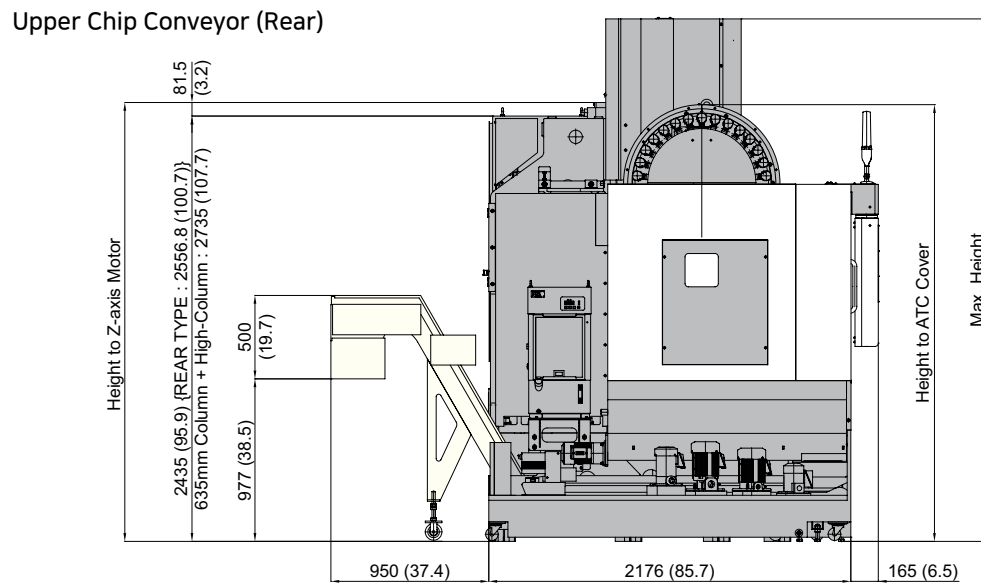
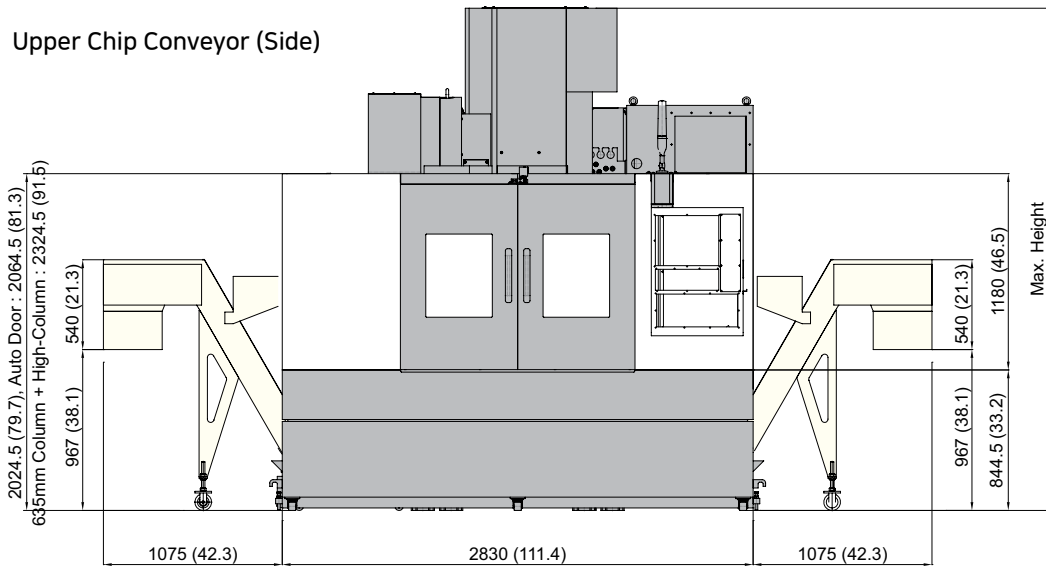

*Level Block Height : Upper Chip Conveyor (Side)_80mm (3.1"), Upper Chip Conveyor (Rear)_200mm (7.9")

Height Item	Max. Height	Height to Magazine Cover			Shipping Height	Spindle Motor Height
		30 tool	40 tool	60 tool		
Upper/Side	3,028 (119.2")	2,510 (98.8")	2,710 (106.7")	2,380 (93.7")	2,516.5 (99.1")	2,740 (107.9")
Upper/Rear	3,148 (123.9")	2,630 (103.5")	2,830 (111.4")	2,500 (98.4")	2,636.5 (103.8")	2,860 (112.6")

SPECIFICATIONS

External Dimensions (KF6700M)

unit : mm(in)

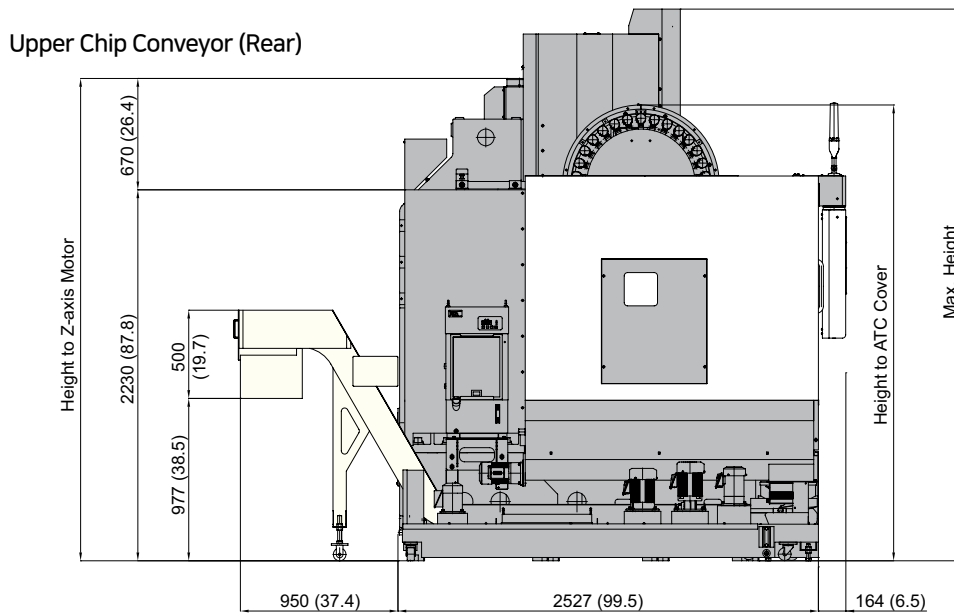
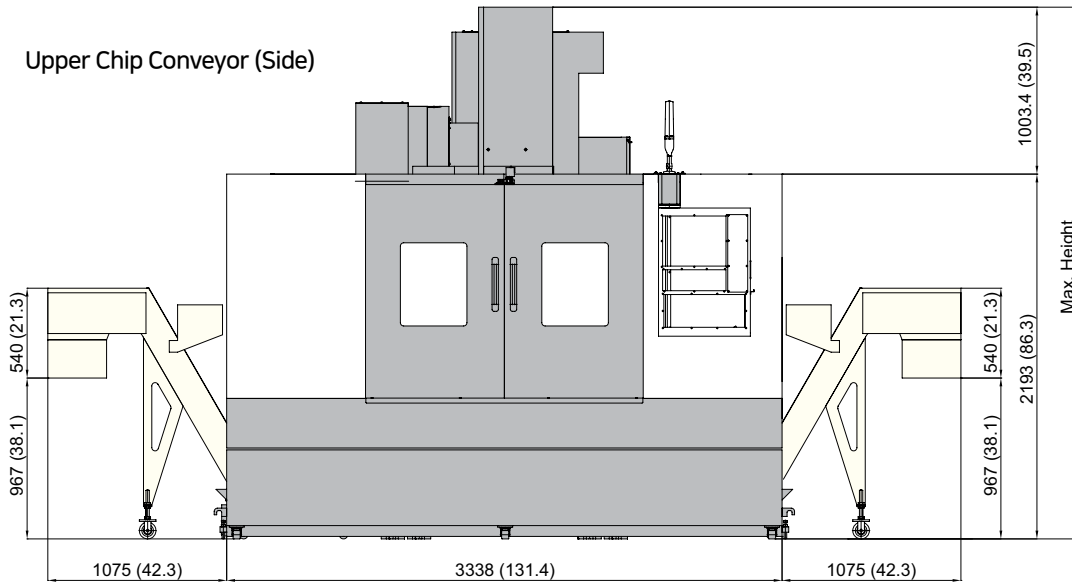

*Level Block Height : Upper Chip Conveyor (Side)_80mm (3.1"), Upper Chip Conveyor (Rear)_200mm (7.9")

Height Item	Max. Height	Height to Magazine Cover			Shipping Height	Spindle Motor Height
		30 tool	40 tool	60 tool		
Upper/Side	3,196 (125.8")	2,620 (103.1")	2,820 (111")	2,380 (93.7")	2,900 (114.2")	2,780 (109.4")
Upper/Rear	3,316 (130.6")	2,740 (107.9")	2,940 (115.7")	2,500 (98.4")	3,020 (118.9")	2,900 (114.2")

SPECIFICATIONS

Table Dimensions

unit : mm(in)

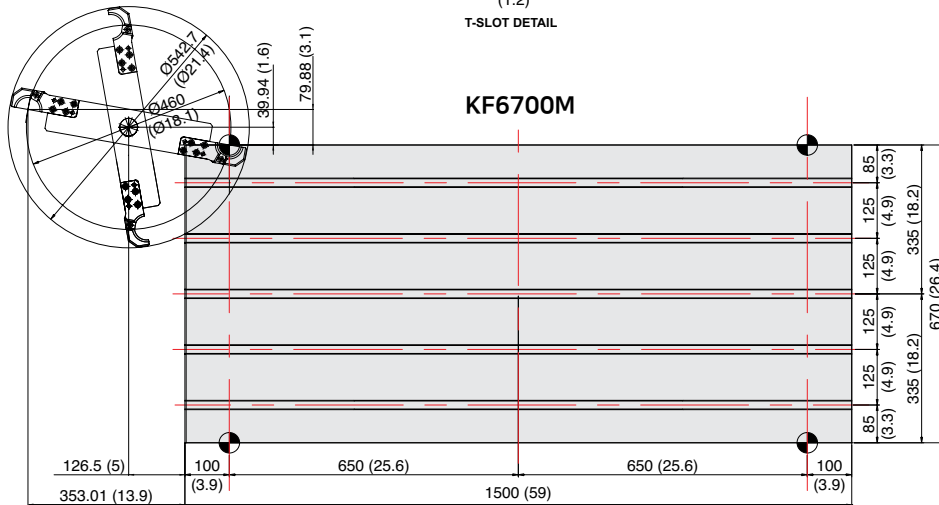
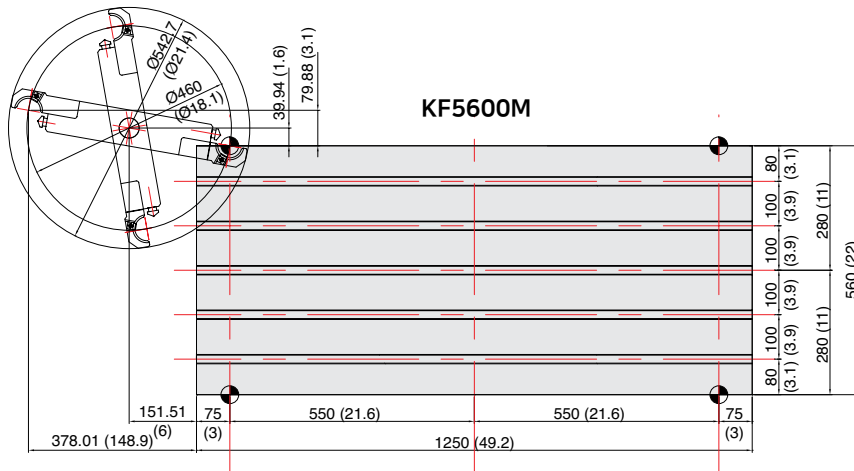

SPECIFICATIONS

Specifications

[]: Option

ITEM			KF5600M	KF6700M
TABLE	Table Size (L×W)	mm(in)	1,250×560 (49.2"×22")	1,500×670 (59"×26.4")
	Maximum Load Capacity	kg(lb)	1,000 (2,205)	1,300 (2,866)
SPINDLE	Spindle Taper	-	BBT40 [HSK-A63]	
	Spindle RPM	r/min	20,000	
	Spindle Power Output (Max./Cont.)	kW(HP)	22/18.5 (30/25)	
	Spindle Torque (Max./Cont.)	N·m(lbf·ft)	98/80 (72.3/59)	
	Spindle Driving Method	-	Built-in	
FEED	Travel (X/Y/Z)	mm(in)	1,100/560/520 (43.3"/22"/20.5")	1,300/670/635 (51.2"/26.4"/25")
	Rapid Traverse Rate (X/Y/Z)	m/min	36/36/30	
	Distance from Table Top to SP. Nose	mm(in)	150 ~ 670 (5.9" ~ 26.4")	150 ~ 785 (5.9" ~ 30.9")
	Distance from Column to SP. center	mm(in)	635 (23.4")	690 (27.2")
	Slide Type	-	ROLLER TYPE LM GUIDE	
ATC	Number of Tools	ea	30 [40, 60]	
	Tool Shank	-	BBT40 [HSK-A63]	
	Max. Tool Dia. (W.T / W.O)	mm(in)	30T : Ø80/Ø125 [40T : Ø76/Ø125] [60T : Ø75/Ø127] (30T : Ø3.1"/Ø4.9" [40T : Ø3"/Ø4.9"] [60T : Ø3"/Ø5"])	
	Max. Tool Length	mm(in)	300 (11.8")	
	Max. Tool Weight	kg(lb)	8 (17.6)	
	Tool Selection Method	-	RANDOM [FIXED]	
	Tool Change Time	T-T	sec	1.3
C-C		sec	3.2	3.5
TANK CAPACITY	Coolant Tank	ℓ (gal)	350 (92.5)	370 (97.7)
	Lubricating Tank	ℓ (gal)	4 (1)	
	Hydraulic Tank	ℓ (gal)	15 (4)	
POWER SUPPLY	Air Consumption (0.5MPa)	ℓ /min(gal)	110 (29)	
	Electric Power Supply	KVA	32	
	Thickness of Power Cable	mm ²	Over 35	
	Voltage	V/Hz	220/60 (200/50*)	
MACHINE	Floor Space (L×W)	mm(in)	2,830×2,176 (111.4"×85.7")	3,338×2,527 (131.4"×99.5")
	Height	mm(in)	3,028 (119.2")	3,196 (125.8")
	Weight	kg(lb)	6,500 (14,330)	7,600 (16,755)
NC	Controller	-	FANUC 31i-B	

*] Using 50Hz voltage instead of 60Hz may lower the output of motors. (excluding servo motors and inverter motors)
Specifications are subject to change without notice for improvement.

CONTROLLER

FANUC 31i-B

[]: Option ☆ Needed technical consultation

Controlled axis / Display / Accuracy Compensation	
Control axis	3 axis (X, Y, Z) [4 axis (X, Y, Z, A)] [5 axis (X, Y, Z, A, C)]
Simultaneously controlled axis	3 axis [Max. 4 axis]
Least setting Unit	X, Y, Z axis : 0.001 mm (0.0001 inch) B axis : 1 deg [0.001] deg
Least input increment	X, Y, Z axis : 0.001 mm (0.0001 inch) B axis : 1 deg [0.001] deg
Inch / Metric conversion	G20 / G21
High response vector control	
Interlock	All axis / Each axis
Machine lock	All axis
Backlash compensation	± 0 ~ 9999 pulses (Rapid traverse / Cutting feed)
Position switch	
LCD / MDI	15 inch color LCD
Feedback	Absolute motor feedback
Stored stroke check 1	Over travel
Stored pitch error compensation	
Operation	
Automatic operation (Memory)	
MDI operation	
DNC operation	Needed DNC software / CF card
Program restart	
Wrong operation prevention	
Program check function	Dry run, Program check Z axis Machine lock, Stroke check before move
Single block	
Search function	Program Number / Sequence Number
Interpolation functions	
Nano interpolation	
Positioning	G00
Linear interpolation	G01
Cylindrical interpolation	G02, G03
Exact stop mode	Single : G09, Continuous : G61
Dwell	G04, 0 ~ 9999.9999 sec
Skip	G31
Reference position return	1st reference, G28 2nd reference, G27 Ref. position check, G30
Thread synchronous cutting	G33
Helical interpolation	Circular + Linear interpolation 2 axis(max.)
Feed function / Acc. & Dec. control	
Manual feed	Rapid traverse Jog : 0~5,000mm/min (197 ipm) Manual handle : x1, x10, x100 pulses Reference position return
Cutting Feed command	Direct input F code
Feedrate override	0 ~ 200% (10% Unit)
Rapid traverse override	F0% (F1%), F25%, F50%, F100%
Override cancel	
Feed per minute	G94
Feed per revolution	G95
Look-ahead block	40 Block 200 Block (Mold)
Program input	
Tape Code	EIA / ISO
Optional block skip	1 ea
Absolute / Incremental program	G90 / G91
Program stop / end	M00, M01 / M02, M30
Maximum command unit	± 999,999.999 mm (± 99,999.9999 inch)
Plane selection	X-Y, G17 / Z-X, G18 / Y-Z, G19
Workpiece coordinate system	G52, G53, 6 pairs (G54 ~ G59)
Manual absolute	Fixed ON
Programmable data input	G10
Sub program call	10 folds nested
Custom macro	#100 ~ #149, #500 ~ #549
G code system	A
Programmable mirror image	G51.1, G50.1
G code preventing buffering	G4.1
Including Chamfering / Corner R	
Canned cycle	G73, G74, G76, G80 ~ G89
Coordinate rotation	G68, G69

Auxiliary function / Spindle speed function	
Auxiliary function	M 4 digit
Level-up M Code	Multi / Bypass M code
Spindle speed command	S 5 digit, Binary output
Spindle override	0% ~ 150% (10% Unit)
Spindle orientation	M19
FSSB high speed rigid tapping	
Tool function / Tool compensation	
Tool function	Max. T 8 digit
Tool life management	256 pairs ☆
Tool offset pairs	64 pairs
Tool nose radius compensation	G40, G41, G42
Tool nose length compensation	G43, G44, G49
Tool offset memory C	Tool length, diameter, abrasion (length, diameter)
Tool length measurement	Z axis Input C
Editing function	
Part program storage size	640m (256KB)
No. of registerable programs	500 ea
Program protect	
Background editing	
Extended part program editing	Copy, move and change of NC program
Memory card program edit	
Data input / output & Interface	
I/O interface	CF card, USB memory Embedded Ethernet interface
Screen hard copy	
External message	
External key input	
External workpiece number search	
Automatic data backup	
Setting, display and diagnosis	
Self-diagnosis function	
History display	Alarm & Operator message & Operation
Run hour / Parts count display	
Maintenance information	
Actual cutting feedrate display	
Display of spindle speed / T code	
Graphic display	
Operating monitor screen	Spindle / Servo load etc.
Power consumption monitoring	Spindle & Servo
Spindle / Servo setting screen	
Multi language display	Support 20 languages
Display language switching	Selection of 5 optional Languages
LCD Screen Saver	Screen saver
Processing select	Speed/rigidity setting

Option

Additional optional block skip	9 ea ☆
Fast ethernet	Needed option board
Data server	Needed option board
Protection of data at 8 levels	
Sub Spindle control	
Polar coordinate command	G15, G16
Polar coordinate interpolation	G12.1, G13.1
Cylindrical interpolation	G07.1
One-way positioning	G60
Stored stroke check 2, 3	
Inverse-time feed	G93
Scaling	G50, G51
Manual guide i	Conversational auto program
Handle interrupt	
Manual handle feed	2/3 units
Additional custom macro variables	#100~#199, #500~#999
Retraction for rigid tapping	#100~#199, #500~#999, #98000~#98499
Tool offset number	Max. 2000 pair ☆
Program storage capacity	512KB ~ 8MB ☆
Program registration number	Max. 4000 ea ☆
Additional work coordinate	48 pair (G54.1 P1 ~ P48)
AICC II	200 block 400 / 600 / 1000 block ☆

Figures in inch are converted from metric values.

The FANUC controller specifications are subject to change based on the policy of company CNC supplying.

GLOBAL NETWORK



WIA MACHINE TOOLS

Headquarter / R&D Center 106, Yongji-ro, Seongsan-gu, Changwon-si, Gyeongsangnam-do, Republic of Korea TEL : +82 55 225 9999

Overseas Sales Team 13, Iljik-ro 12beon-gil, Gwangmyeong-si, Gyeonggi-do, Republic of Korea TEL : +82 55 225 9645

OVERSEAS OFFICES

America corp. 450 Commerce Blvd, Carlstadt, NJ 07072, USA TEL : +1-201-987-7298

Europe GmbH Alexander-Fleming-Ring 57, 65428 Russelsheim Germany TEL : +49-0-6142-9256-0

China Company No.16 Fenghuang Road, Fenghuang Town, Zhangjiagang City, Jiangsu Province, China TEL : +86-21-6427-9885

CIS Branch Office 050051, Kazakhstan, Almaty, Elebekova street 10, B.3 Office no. 103 TEL : +7-727-355-7133

India Branch Office #4/169, 1st Floor, LOTTE BLDG, Rajiv Gandhi Salai, (OMR), Kandanchavadi, Chennai - 600096, Tamilnadu, India TEL : +91-76-0490-3348

WIA MACHINE TOOLS



home page



facebook



youtube



instagram



linkedin